

DCCC

DEĐİŐTİRİLEBİLİR UÇLU PARMAK FREZE
DERİN KENAR FREZELEME VE KANAL AÇMA İÇİN



DCCC

DCCC TİP PARMAK FREZE TASARIM ÖZELLİKLERİ



PERFORMANS VE GÜVENİRLİLİK İÇİN YÜKSEK RİJİDLİKDE TAKIM

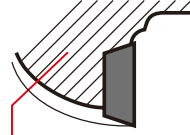

Ekstra gövde boşluğu talaş sıkışma olasılığını düşürür.

AVANTAJLARI

- Gürültüyü önleyen farklı açılı helis kanalları
- Yüksek performans ve güvenilirlik için dayanıklı takım
- Derin 2D profil frezelemede yüksek verimlilik

CCMX KESİCİ UCUN 80°'LİK 2 KÖŞESİ "A" KANALI İÇİNDE VE 100°'LİK 2 KÖŞESİ "B" KANALI ÜSTÜNDE OLMAK ÜZERE 4 KENARIN TAMAMI KESİCİ KENAR OLARAK KULLANILABİLİR.

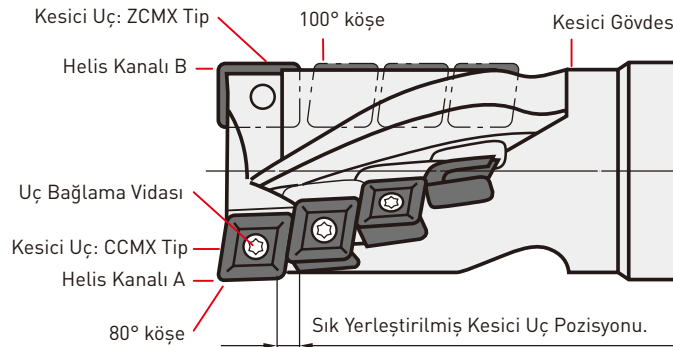

DCCC



DERİN KENAR FREZELEME VE KANAL AÇMA İÇİN DEĞİŞTİRİLEBİLİR UÇLU PARMAK FREZE

P M K

Ø25 (Düz Şaftlı)

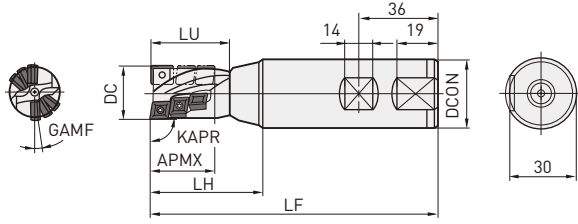

Ø32 (Düz Şaftlı)

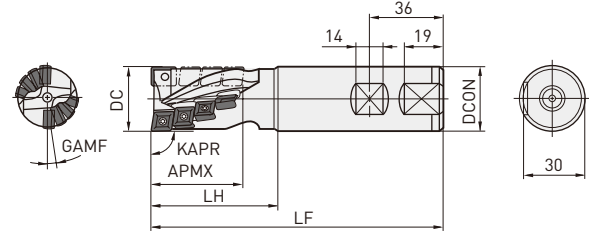

Ø40 (Düz Şaftlı)

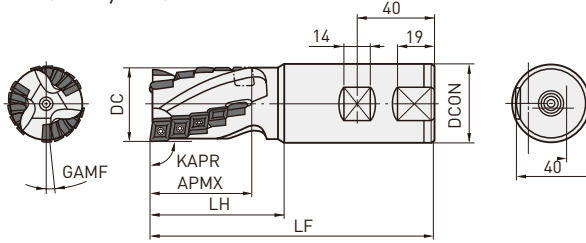

Yalnızca sağ takım .

Sipariş Numarası	Stok	APMX	DC	DCON	LF	LH	LU	ZNF	ZNP	ZEFF	GAMF	Çevresel ve Zemin Kesici Uçları		Zemin Kesici Ucu (Sadece bir adet)	
												CCMX08 3508EN-A	CCMX09 T308EN-○	ZCMX08 3508ER-A	ZCMX09 T308ER-○
DCCCR2506S32	●	27	25	32	130	50	36	2	6	2	8°	5	-	1	-
DCCCR2510S32	●	44	25	32	150	70	56	2	10	2	8°	9	-	1	-
DCCCR3208S32	●	43	32	32	140	60	-	2	8	2	8°36'	-	7	-	1
DCCCR3212S32	●	63	32	32	160	80	-	2	12	2	8°36'	-	11	-	1
DCCCR4015S40	●	53	40	40	150	70	-	3	15	3	5°31'	-	14	-	1
DCCCR4015S42	★	53	40	42	150	70	-	3	15	3	5°31'	-	14	-	1
DCCCR4024S40	●	83	40	40	180	100	-	3	24	3	5°31'	-	23	-	1
DCCCR4024S42	★	83	40	42	180	100	-	3	24	3	5°31'	-	23	-	1



YEDEK PARÇALAR







Takım Numarası	Uç Vidası	Anahtar	Çevresel ve Zemin Kesici Uç	Zemin Kesici Uç (Sadece bir adet)
DCCR25	CS300890T	TKY08DS	CCMX083508EN-A	ZCMX083508ER-A
DCCR32	CS350990T	TKY10DS	CCMX09T308EN-A / B	ZCMX09T308ER-A / B
DCCR40				

* Sıkma Torku (N • m): CS300890T=1.0, CS350990T=2.5

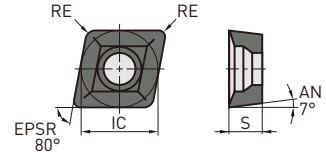
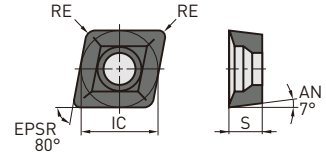
DCCC

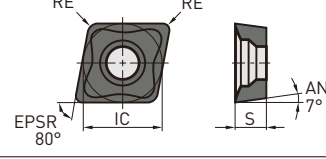
KESİCİ UÇLAR

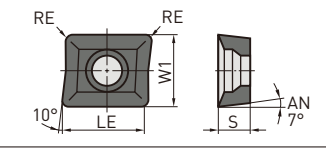
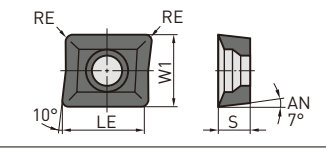
Malzeme	Kesme Şartları:				
	● : Düz Darbesiz Kesme	● : Genel Kesme	✱ : Darbeli Kesme	E : Yuvarlak	
P	Çelik	●	●	●	●
M	Paslanmaz Çelik	●	●	●	●
K	Dökme Demir	✱	✱	✱	✱

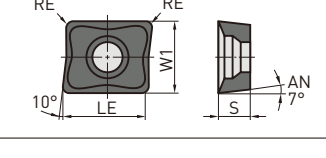
Şekil	Sipariş Numarası	Sınıf	Honlama	F7030	VP15TF	UP20M	UTi20T	LE	W1	IC	S	RE	Geometri
	CCMX083508EN-A	M	E	●	★	★	★	-	-	7.94	3.5	0.8	
	CCMX09T308EN-A	M	E	●	●	★	★	-	-	9.525	3.97	0.8	
	CCMX09T308EN-B	M	E	●	★	★	★	-	-	9.525	3.97	0.8	
	Güçlü Kesme Kenarlı Tip												
	ZCMX083508ER-A	M	E	●	★	★	★	10.4	7.94	-	3.5	0.8	
	ZCMX09T308ER-A	M	E	●	●	★	★	12	9.525	-	3.97	0.8	
	ZCMX09T308ER-B	M	E	●	★	★	★	12	9.525	-	3.97	0.8	
	Güçlü Kesme Kenarlı Tip												

DCCC

ÖNERİLEN KESME KOŞULLARI

Kesme Modu A : Kanal Frezeleme (Kesme Boyu Standart Tipi)

Kesme Modu B : Dik Kenar Frezeleme (Kesme Boyu Standart Tipi)

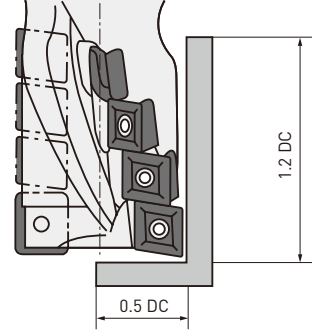
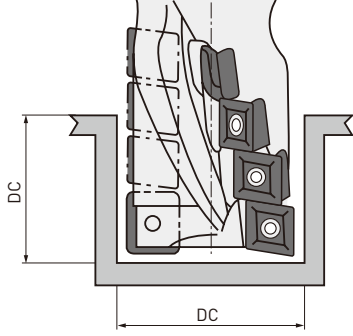

Malzeme	Sertlik	Kalite	Kesme Modu	Vc	Vf			
					Ø 25 mm	Ø 32 mm	Ø 40 mm	
P	Yumuşak Çelik	≤ 180HB	VP15TF	A	180 (100-250)	120 (100-140)	120 (100-140)	120 (100-140)
			VP15TF	B	180 (100-250)	200 (180-220)	200 (180-220)	230 (200-250)
	Karbon Çeliği Alaşımli Çelik	180-280HB	VP15TF	A	180 (100-250)	120 (100-140)	120 (100-140)	140 (120-150)
			VP15TF	B	180 (100-250)	150 (120-180)	150 (120-180)	180 (150-200)
Yüksek Alaşımli Çelik	280-350HB	VP15TF	A	180 (100-250)	100 (80-120)	100 (80-120)	130 (100-150)	
		VP15TF	B	180 (100-250)	120 (100-140)	120 (100-140)	150 (120-180)	
M	Paslanmaz Çelik	≤200HB	VP15TF	A	140 (100-180)	100 (80-120)	100 (80-120)	130 (100-150)
			VP15TF	B	140 (100-180)	120 (100-140)	120 (100-140)	150 (120-180)
K	Dökme Demir	Kopma Mukavemeti ≤450 MPa	VP15TF	A	160 (100-220)	200 (180-220)	200 (180-220)	230 (200-250)
			VP15TF	B	160 (100-220)	230 (200-250)	230 (200-250)	260 (240-280)

DCCC

GÜÇ TÜKETİMİ

- Tezgah gücüne uygun koşulları seçmek için lütfen aşağıdaki tabloyu referans alın.
- Talaş Tahliyesi Q (mm³/dk.)=Tabla İlerleme Hızı x Kesme Derinliği x Kesme Genişliği :1000

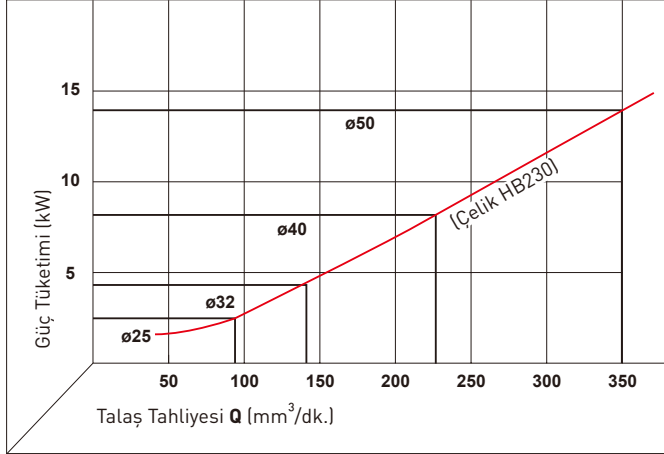

KESME BOYUNUN YÜKSEKLİĞİNE GÖRE KULLANIM

- Takım serbest boyunun uzun, kesme derinliği ve genişliğinin de yüksek olduğu uygulamalar, gürültülü çalışma ve takım kırılmalarına neden olur.
- Eksenel kesme derinliği miktarı, yanal kesme genişliğinden yüksek tutulmalıdır. (Aşağıdaki görsele bakın.)

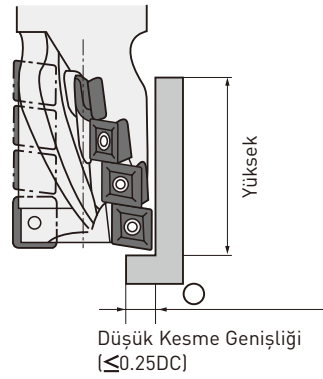
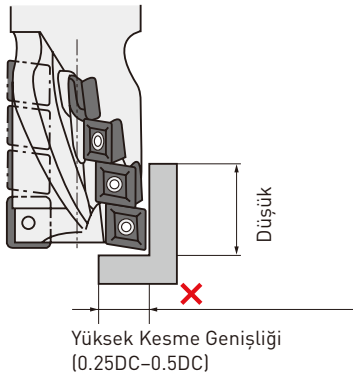

GERMANY

MMC HARTMETALL GMBH
Comeniusstr. 2 . 40670 Meerbusch
Phone +49 2159 91890 . Fax +49 2159 918966
Email admin@mmchg.de

U.K.

MMC HARDMETAL U.K. LTD.
Mitsubishi House . Galena Close . Tamworth . Staffs. B77 4AS
Phone +44 1827 312312 . Fax +44 1827 312314
Email sales@mitsubishicarbide.co.uk

SPAIN

MITSUBISHI MATERIALS ESPAÑA, S.A.
Calle Emperador 2 . 46136 Museros/Valencia
Phone +34 96 1441711 . Fax +34 96 1443786
Email comercial@mmevalencia.es

FRANCE

MMC METAL FRANCE S.A.R.L.
6, Rue Jacques Monod . 91400 Orsay
Phone +33 1 69 35 53 53 . Fax +33 1 69 35 53 50
Email mmfsales@mmc-metal-france.fr

POLAND

MMC HARDMETAL POLAND SP. Z O.O
Al. Armii Krajowej 61 . 50-541 Wrocław
Phone +48 71335 1620 . Fax +48 71335 1621
Email sales@mitsubishicarbide.com.pl

RUSSIA

MMC HARDMETAL OOO LTD.
Electrozavodskaya St. 24 . build. 3 . Moscow . 107023
Phone +7 495 725 58 85 . Fax +7 495 981 39 79
Email info@mmc-carbide.ru

ITALY

MMC ITALIA S.R.L.
Viale Certosa 144 . 20156 Milano
Phone +39 0293 77031 . Fax +39 0293 589093
Email info@mmc-italia.it

TURKEY

MMC HARTMETALL GMBH ALMANYA - İZMİR MERKEZ ŞUBESİ
Adalet Mahallesi Anadolu Caddesi No: 41-1 . 15001 35530 Bayraklı /İzmir
Phone +90 232 5015000 . Fax +90 232 5015007
Email info@mmchg.com.tr

www.mitsubishicarbide.com | www.mmc-hardmetal.com

DAĞITICI:

□

□

L

┘